

ISA828

MkII

Eight channel mic pre and optional A-D card with Dante

User Guide



Version 1.01

FA0145-04

Focusrite[®]
pro.focusrite.com

CONTENTS

About this User Guide	3
INTRODUCTION	4
ISA 828 MKII CONTROLS AND FEATURES	5
Front Panel	5
Channel Controls	5
Input Selection	5
Mic Input	5
Line Input	6
Instrument Input	6
Z In (Input Impedance)	6
+48V	6
Phase	6
HPF (High-Pass Filter)	6
Insert	6
Channel Meters	7
Meter Calibration	7
Rear Panel	8
AC Mains Inlet	8
Microphone Inputs	8
Line Inputs	8
Analogue Outputs	8
A-D inputs	8
Meter Trim	8
A-D Option Card Slot	8
A-D Option Card	9
A-D Card Clock and Sync Switches	10
PHYSICAL CHARACTERISTICS	11
Power Requirements	11
APPENDICES	12
1. Connector Pinouts	12
2. Preamp Input Impedance	14
3. Pro Tools Interfacing	16
PERFORMANCE AND SPECIFICATIONS	17
Focusrite RedNet Warranty and Service	19

About this User Guide

This user guide applies to the ISA 828 MkII mic pre. It provides information about installing and using the unit, and how it can be connected into your system.

Also included is information relating to the optional ISA ADN8 A-D interface card, which will allow audio from the Mic pre to be added to a Dante network.

If you feel that additional information might be of assistance, be sure to consult the site: <https://pro.focusrite.com/technical-support>, which contains a comprehensive collection of common technical support queries.

Pro Tools® and Pro Tools | HD™ are trademarks or registered trademarks of Avid Technology, Inc. or its subsidiaries in the United States and/or other countries.

Dante® and Audinate® are registered trademark of Audinate Pty Ltd.

Box Contents

- ISA 828 MkII unit
- AC power lead
- Safety information cut sheet

INTRODUCTION

Thank you for purchasing the Focusrite ISA 828 MkII.



The ISA 828 MkII is a high quality eight channel microphone preamplifier, which can be used to record microphone, line-level or instrument sources. Microphones and line-level sources for all eight inputs are connected via the rear panel, whilst instrument inputs, available on channels 1–4, can be plugged directly into the front panel jack sockets.

The front panel also features gain and other settings such as phantom power and impedance for each of the eight analogue inputs. LED metering is provided on each channel in dBFS, to indicate when the level is reaching the digital clipping point – a dial for calibration is provided on the rear panel.

To maintain pristine Focusrite quality in the digital domain, an Analogue-to-Digital interface card may be fitted into the option slot on the rear panel. This provides access to a Dante network and features AES3, S/PDIF and ADAT signals.

With the A-D card installed, the internal/external clock sample rate and sync source can be selected using the switches on the front panel.

ISA 828 MKII CONTROLS AND FEATURES

Front Panel

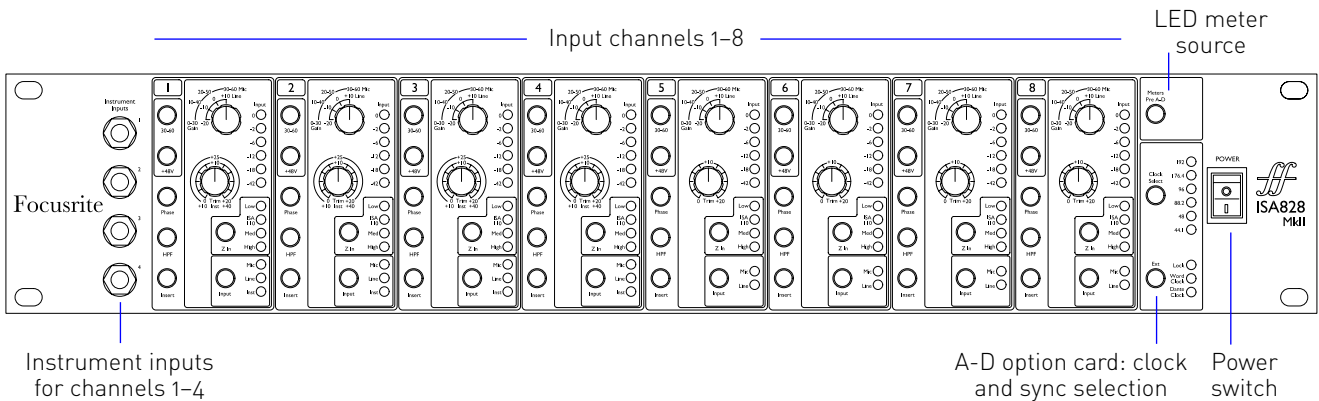

Channel Controls

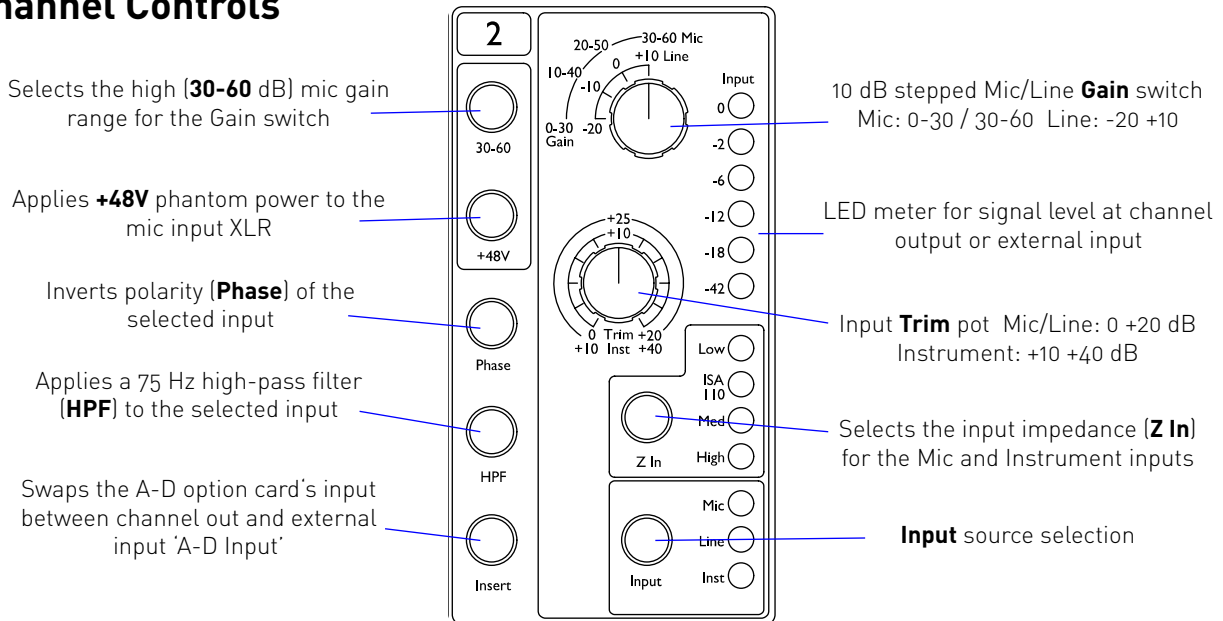

Input Selection

Each press of the **Input** button steps through the available input sources: Mic/Line/Instrument for channels 1-4, Mic/Line for channels 5-8.

Mic Input

The **Gain** switch sets the mic gain in 10 dB steps. Its range is either 0-30 dB or 30-60 dB when the **30-60** switch is pressed. An additional 0-20 dB of fine gain adjustment is available by using the **Trim** control.

To avoid an excessive jump in level, it is recommended that the stepped Gain switch is turned to minimum before pressing the 30-60 switch.

Before starting a recording, or if used for PA work, set the Trim control to near its centre position. This will allow for some gradual gain adjustment up or down without the use of the stepped control.

Line Input

The **Gain** switch sets the gain at between -20 dB and +10 dB in 10 dB steps. Continuous gain adjustment of up to 20 dB can be added using the **Trim** control.

Instrument Input

The Instrument inputs are accessed via standard 1/4" mono jacks on the front panel. The level is set using the **Trim** control only and is continuously adjustable from +10 dB to +40 dB.

Refer to the appendix on page 12 for connector pinouts.

Z In (Input Impedance)

With Mic input selected, pressing the **Z In** button steps through the four transformer preamp input impedance options. The values are shown in the table.

For additional information on impedance selection see Appendix 2, "Preamp Input Impedance" on page 14.

Low	600 Ω
ISA 110	1.4 k Ω
Med	2.4 k Ω
High	6.8 k Ω

Mic Impedance

With Instrument input selected, pressing the switch toggles between High and Low impedance settings, as shown in the lower table.

Low	470 k Ω
High	2.4 M Ω

Instrument Impedance

The Line input impedance is fixed at 10 k Ω and is not affected by the Z In switch.

+48V

Pressing the **+48V** button applies phantom power to the Mic input XLR. This switch does not affect the Line or Instrument inputs.

If you are unsure whether your microphone requires phantom power please refer to its handbook. Certain microphones (most notably ribbon and unbalanced mics) could be damaged by applying phantom power.

Phase

Pressing **Phase** inverts the polarity of the selected input. This can be useful when multiple mic are used in close proximity (ie., on a drum kit).

HPF (High-Pass Filter)

Pressing **HPF** inserts the 18 dB/octave 75 Hz high-pass filter into channel path; it is applied to whichever input is selected.

The HPF is useful for removing any unwanted low frequencies, eg., rumble transmitted through floor mounted mic stands, etc.

Insert

Pressing a channel's **Insert** button switches the A-D option card's input source from the channel output to the external input – ie., the same channel in the 'A-D Inputs' connector.

The channel's output is unaffected, allowing its signal to be processed externally and then returned to the A-D card for conversion.

The return signal levels can monitored on the channel LED meters when the Meters Pre A-D switch is pressed – see Channel Meters on the next page.

Channel Meters

The LED meters can be switched to display signal level at two different audio paths, determined by the setting of the **Meters Pre A-D** switch on the front panel:

- Meters Pre A-D switch **OFF** – LEDs show the signal at the channel output. This is the default setting and shows the level being sent to external recorders/outboard effects.
- Meters Pre A-D switch **ON** – LEDs now show the signal level received at the A-D Input connector on the rear panel. This mode is useful when the A-D option card is installed and allows the incoming signals to be monitored before being converted by the digital card.

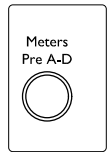

The LED meter scale is in dBFS, ie., the dB level relative to maximum output (reached when the red '0' LED illuminates).

The default calibration for the meters is for '0' to indicate a signal level of 22 dBu (which is the A-D card's maximum input level). See *Meter Calibration* below.

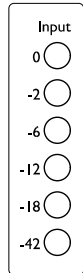

Meter Calibration

The signal level at which 0 dBFS is displayed can be adjusted by using the **Meter Trim** control on the rear panel.

The default setting of 0 dBFS = 22 dBu occurs when the knob is in its central, detent position – to correspond with the maximum input level of the A-D card.

Rotating the Meter Trim knob will set the value at between 0 dBFS = 15 dBu (fully anticlockwise) and 0 dBFS = 26 dBu (fully clockwise).

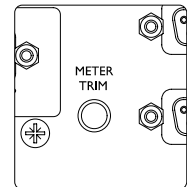

Rear Panel

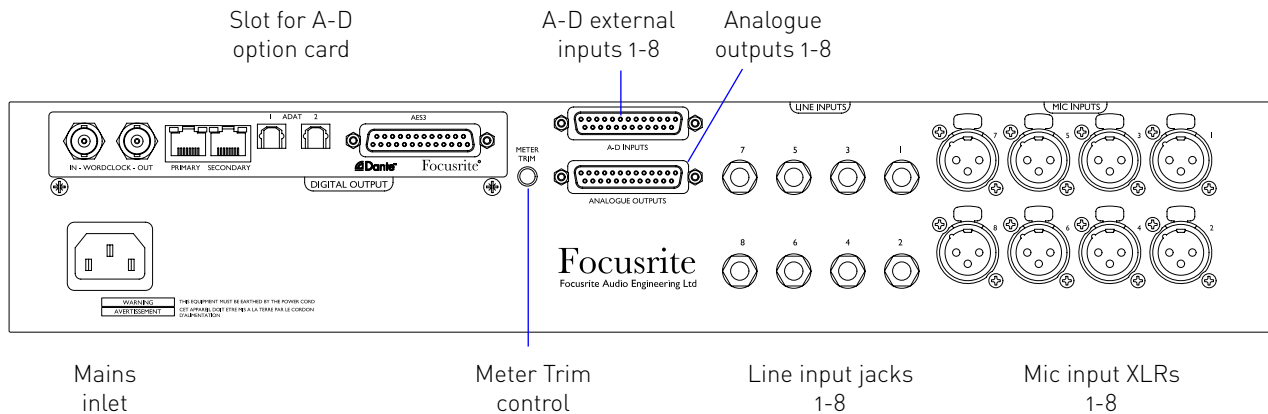

AC Mains Inlet

Standard IEC receptacle for AC mains. ISA 828 MkII features a 'Universal' PSU, enabling it to operate on any supply voltage between 100 V and 240 V AC.

Microphone Inputs

Eight latching XLR-3 female connectors.

Line Inputs

Eight balanced 1/4" TRS jack sockets.

Analogue Outputs

Channel outputs 1–8 on DB25 female connector. These outputs are linked internally to the A-D option card inputs, except when the **Insert** switches are pressed.

A-D inputs

Eight analogue inputs to the A-D option card on DB25 female connector. Inputs are enabled individually by pressing channel **Insert** switches.

Both DB25 connectors are wired according to the AES59 Standard (also known as the TASCAM Analogue standard). Refer to the Appendix on page 12 for connector pinouts.

Meter Trim

Allows the channel LED meter reading at full scale to be adjusted between 15 dBu and 26 dBu. At the central detented position the reading will be 22 dBu, which matches the maximum input level of the A-D card. Also see *Meter Calibration* on page 7.

A-D Option Card Slot

Slot for ISA ADN8 analogue to digital conversion card. The card allows audio channels from the ISA 828 MkII to be added to a Dante network. It also provides AES3, S/PDIF and ADAT signals.

See the following page for A-D card details.

A-D Option Card

The optional ISA ADN8 A-D card can be retrofitted to an ISA 828 MkII at any time. Engineering experience is not required as the card can easily be installed by the user.

Note that the ISA 828 MkII does not support the earlier ISA 8-Channel A-D card.

Once fitted, configuration of the card is carried out over the network using either RedNet Control or the Dante Controller software application.

The fitting instructions and network software applications are included with the A-D card option.

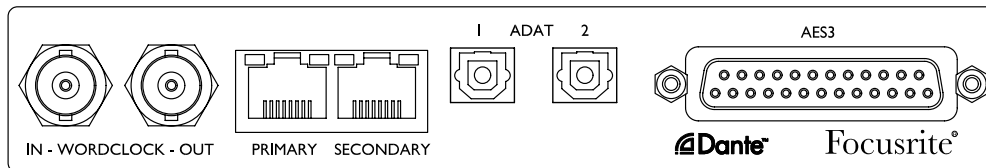

Word Clock – Input

Allows the card to be synchronised to an external Word Clock source via the BNC connector.

Word Clock – Output

Provides an output of the external Word Clock source connected at the “Word Clock In” BNC connector or, transmits the internal sample frequency of the A-D card.

- When the ISA 828 MkII is being used as a follow device within a larger digital system, the Word Clock Out connector can be used to pass on the external word clock signal to the next device.
- When the unit is not following another device and is in Internal Clock mode, the Word Clock Out connector outputs the sample frequency selected on the ISA 828 MkII front panel.

Primary Network Port

Latching RJ45 connector for the Dante network. Use standard Cat 5e or Cat 6 network cable to connect to a local Ethernet switch to connect the ISA ADN8 to the Dante network. Adjacent to each network socket are LEDs which illuminate to indicate a valid network connection and network activity.

Secondary Network Port

Secondary Dante network connection where two independent Ethernet links are being used (Redundant mode) or an additional port on an integral network switch on the primary network (Switched mode).

ADAT I/O 1 and 2

Two independent 8-channel ADAT optical outputs using standard TOSLINK connectors.

AES3 Outputs 1-8

Eight AES3 outputs on DB25 connector.

See Appendix 1 on page 13 for connector pinouts.

See Appendix 3 on page 16 for Pro Tools interfacing information.

A-D Card Clock and Sync Switches

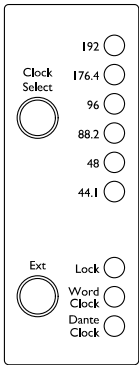

Clock select

Allows the user to select the internal sample frequency: 44.1kHz, 48kHz, 88.2kHz, 96kHz, 176.4kHz, or 192kHz.

Ext

Allows the ISA ADN8 A-D card to follow an external Word Clock source. Press the switch to toggle between standard and Dante clock.

Lock LED

Indicates that the unit is successfully synchronised to the external Word Clock.

PHYSICAL CHARACTERISTICS

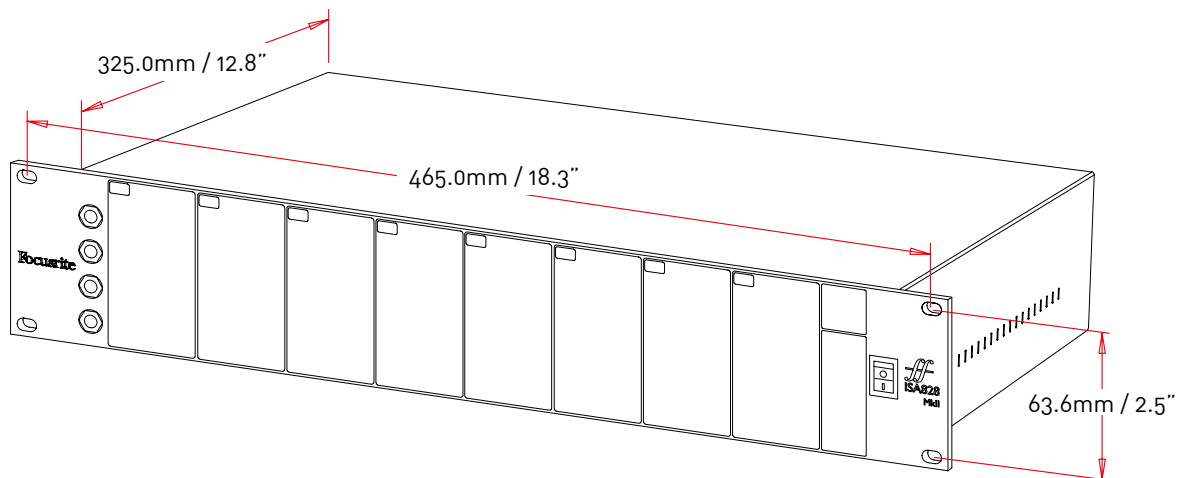

Case dimensions are illustrated in the diagram above.

ISA 828 MkII requires 2U of vertical rack space. Allow an additional 75mm of rack depth behind the unit to allow for cables. ISA 828 MkII weighs 7.05 kg and for installations in a fixed environment (eg., a studio rack), the front-panel rack mountings* will provide adequate support. However, if the unit is to be used in a mobile situation (eg., flight-cased for touring, etc.), it is recommended that side support rails or shelves are used within the rack.

**Always use M6 bolts and cage nuts specifically designed for 19" equipment racks. An Internet search using the phrase "M6 cage nuts" will reveal suitable components.*

Cooling vents are provided at each side; ensure that when mounted in a rack these vents are not obstructed. Do not mount the unit immediately above any other equipment which generates significant heat, for example, a power amplifier.

Note. The maximum operating environmental temperature is 40°C / 104°F.

Power Requirements

ISA 828 MkII is mains powered and incorporates a 'Universal' power supply which can operate on any AC mains voltage from 100 V to 240 V. The AC connection is via a standard 3-pin IEC connector on the rear panel.

A mating IEC cable is supplied with each unit – this should be terminated with a mains plug of the correct type for your country.

Power consumption for ISA 828 MkII is 35 W.

Please note that there are no fuses or other user-replaceable components of any type in any unit. Please refer all servicing issues to the Customer Support Team (see "Customer Support and Unit Servicing" on page 19).

APPENDICES

1. Connector Pinouts

Mic Input

Connector: XLR-3 female

Pin	Signal
1	Screen
2	Hot (+ve)
3	Cold (-ve)

Line Input

Connector: Balanced (TRS) 1/4" Jack socket

Tip Ring Sleeve

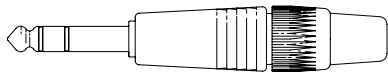

Pin	Signal
Tip	Hot (+ve)
Ring	Cold (-ve)
Sleeve	Ground

Instrument Input

Connector: Unbalanced (TS) 1/4" Jack socket

Tip Sleeve



Pin	Signal
Tip	Hot (+ve)
Sleeve	Ground

Line Outputs / A-D Inputs

Connector: DB25 female (AES59 analogue)

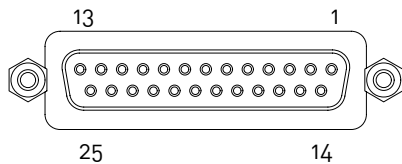

Pin	Signal	
1	Channel 8	+
14	Channel 8	-
2	Ground	
15	Channel 7	+
3	Channel 7	-
16	Ground	
4	Channel 6	+
17	Channel 6	-
5	Ground	
18	Channel 5	+
6	Channel 5	
19	Ground	
7	Channel 4	+
20	Channel 4	-
8	Ground	
21	Channel 3	+
9	Channel 3	-
22	Ground	
10	Channel 2	+
23	Channel 2	-
11	Ground	
24	Channel 1	+
12	Channel 1	-
25	Ground	
13	n/c	

Screw binding-posts use the standard UNC 4/40 thread

ISA ADN8 Option Card:

AES3 Outputs

Connector: DB25 female (AES59 digital)

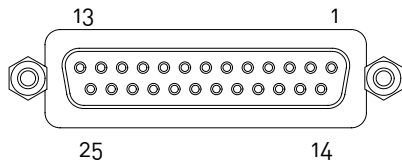

Screw binding-posts use the standard UNC 4/40 thread

Pin	Signal
1	Out channels 7/8 +
14	Out channels 7/8 -
2	Ground
15	Out channels 5/6 +
3	Out channels 5/6 -
16	Ground
4	Out channels 3/4 +
17	Out channels 3/4 -
5	Ground
18	Out channels 1/2 +
6	Out channels 1/2 -
19	Ground
7	In channels 7/8 +
20	In channels 7/8 -
8	Ground
21	In channels 5/6 +
9	In channels 5/6 -
22	Ground
10	In channels 3/4 +
23	In channels 3/4 -
11	Ground
24	In channels 1/2 +
12	In channels 1/2 -
25	Ground
13	n/c

Network 1 & 2

Connector type: RJ-45 receptacle

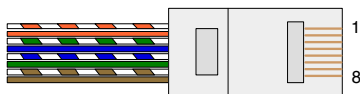

Pin	Cat 5/6 Core
1	White + Orange
2	Orange
3	White + Green
4	Blue
5	White + Blue
6	Green
7	White + Brown
8	Brown

ADAT Optical Interface

Connector: TOSLINK

Word Clock In & Out

Connector: BNC 75Ω

2. Preamp Input Impedance

A major element of the sound of a mic pre is related to the interaction between the specific microphone being used and the type of mic preamp interface technology it is connected to. The main area in which this interaction has an effect is the level and frequency response of the microphone, as follows:

Level

Professional microphones tend to have low output impedances and so more level can be achieved by selecting the higher impedance positions of the ISA 828 MkII mic preamp.

Frequency response

Microphones with defined presence peaks and tailored frequency responses can be further enhanced by choosing lower impedance settings. Choosing higher input impedance values will tend to emphasise the high frequency response of the microphone connected, allowing you to get improved ambient information and high end clarity – even from average-performance microphones. Various microphone/ISA 828 MkII preamp impedance combinations can be tried to achieve the desired amount of colouration for the instrument or voice being recorded. To understand how to use the impedance selection creatively, it may be useful to read the following section on how the microphone output impedance and the mic preamp input impedance interact.

Impedance Setting – Quick Guide

In general the following selections will yield the following results:

High mic preamp impedance settings:

- Will generate more overall level
- Will tend to make low- and mid-frequency response of the microphone flatter
- Will improve high-frequency response of the microphone.

Low preamp impedance settings:

- Will reduce the microphone output level
- Will tend to emphasise the low- and mid-frequency presence peaks and resonant points of the microphone

Switchable Impedance – In Depth Explanation

Dynamic Moving Coil and Condenser Microphones

Almost all professional dynamic and condenser microphones are designed to have a relatively low nominal output impedance of between 150 Ω and 300 Ω when measured at 1 kHz. Microphones are designed to have such low output impedance because the following advantages result:

- They are less susceptible to noise pickup
- They can drive long cables without high frequency roll-off due to cable capacitance

The side-effect of having such low output impedance is that the mic preamp input impedance has a major effect on the output level of the microphone. Low preamp impedance loads down the microphone output voltage, and emphasizes any frequency-related variation in microphone output

impedance. Matching the mic preamp resistance to the microphone output impedance (eg., making a preamp input impedance 200 Ω to match a 200 Ω microphone) still reduces the microphone output and signal to noise ratio by 6 dB, which is undesirable.

To minimise microphone loading, and to maximise signal to noise ratio, preamps have traditionally been designed to have an input impedance about ten times greater than the average microphone, around 1.2 k Ω to 2 k Ω . (The original ISA 110 preamp design followed this convention and has an input impedance of 1.4 k Ω at 1 kHz.) Input impedance settings greater than 2 k Ω tend to make the frequency-related variations of microphone outputs less significant than at low impedance settings. Therefore high input impedance settings yield a microphone performance that is flatter in the low and mid frequency areas and boosted in the high frequency area when compared to low impedance settings.

Ribbon Microphones

The impedance of a ribbon microphone is worthy of special mention, as this type of microphone is affected enormously by preamp impedance. The ribbon impedance within this type of microphone is incredibly low, around 0.2 Ω , and requires an output transformer to convert the extremely low voltage it can generate into a signal capable of being amplified by a preamp. The ribbon microphone output transformer requires a ratio of around 1:30 (primary:secondary) to increase the ribbon voltage to a useful level, and this transformer ratio also has the effect of increasing the output impedance of the mic to around 200 Ω at 1 kHz. This transformer impedance, however, is very dependent upon frequency - it can almost double at some frequencies (known as the resonance point) and tends to roll off to very small values at low and high frequencies. Therefore, as with the dynamic and condenser microphones, the mic preamp input impedance has a massive effect on the signal levels and frequency response of the ribbon microphone output transformer, and thus the 'sound quality' of the microphone. It is recommended that a mic preamp connected to a ribbon microphone should have an input impedance of at least 5 times the nominal microphone impedance.

For a ribbon microphone impedance of 30 Ω to 120 Ω , the input impedance of 600 Ω (Low) will work fine. For 120 Ω to 200 Ω ribbon microphones, the input impedance setting of 1.4 k Ω (ISA 110) is recommended.

3. Pro Tools Interfacing

- Analogue out to Pro Tools | HD

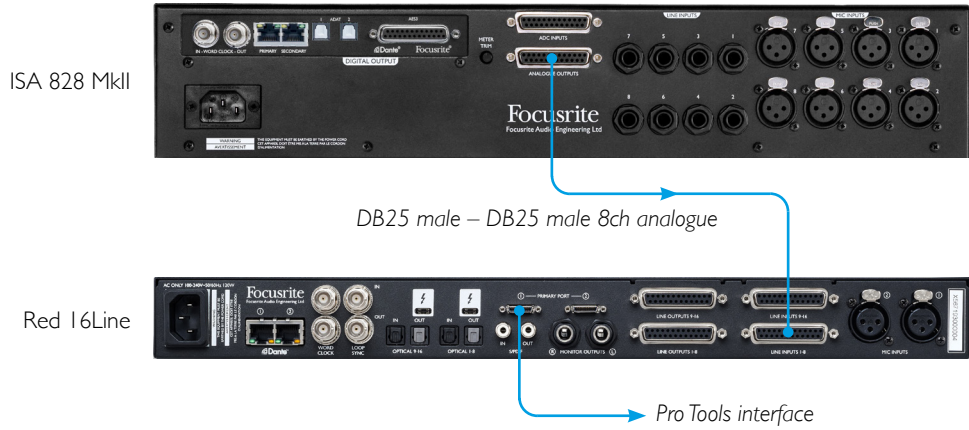

- Dante to Pro Tools | HD

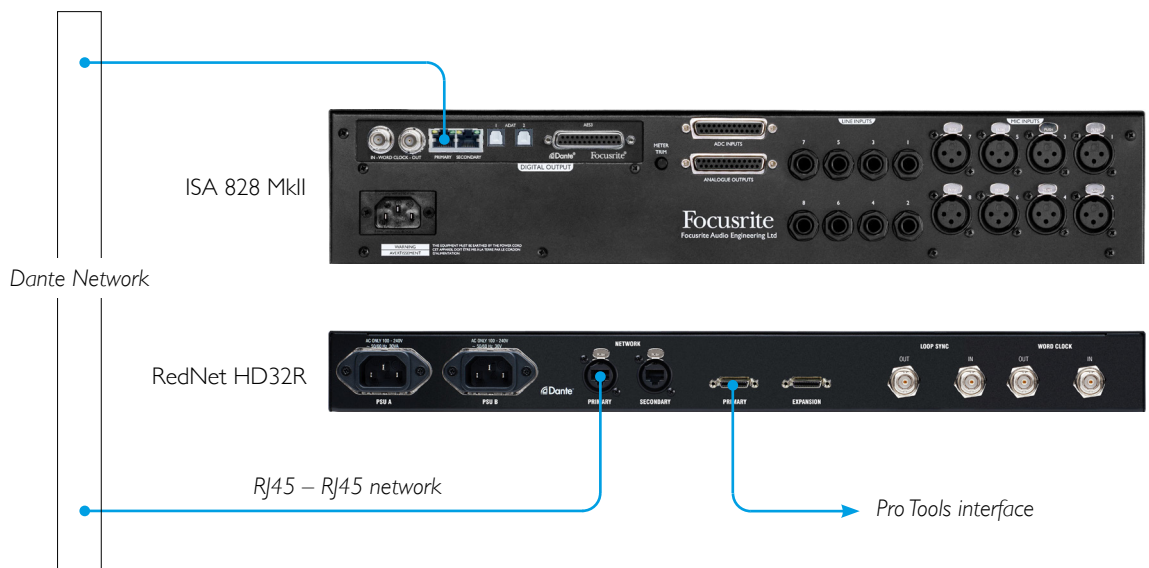

PERFORMANCE AND SPECIFICATIONS

Microphone Inputs	
<i>All measurements taken at minimum gain, Z In: medium, unless otherwise stated. Measurements taken at the analogue outputs</i>	
Gain Range	0 to 30 dB or 30 to 60 dB (with '30-60' switch enabled), in 10 dB steps, plus 0 to 20 dB of continuous trim
Maximum Input Level	+7 dBu
Input Impedance	Transformer balanced, Low: 600 Ω , ISA 110: 1.4 k Ω , Medium: 2.4 k Ω , High: 6.8 k Ω
Signal-to-Noise Ratio	122 dB 'A'-Weighted (typical), <i>maximum gain</i>
Frequency Response	20 Hz – 20 kHz \pm 0.2 dB 10 Hz – 110 kHz \pm 1.5 dB
THD + N	-92 dB (0.0025%) @ -1 dB
High-Pass Filter	75 Hz knee frequency, 18 dB/octave, switchable per channel
EIN	<-123 dBu 'A'-Weighted (typical), <i>maximum gain</i>
Common Mode Rejection Ratio	-93 dB @ 1kHz

Line Inputs	
<i>All measurements taken at minimum gain, Z In: Low, unless otherwise stated, $R_s = 50 \Omega$. Measurements taken at the analogue outputs</i>	
Gain Range	-20 to +10 dB in 10 dB steps, plus 0 to 20 dB continuous trim
Maximum Input Level	+25 dBu
Input Impedance	Electronically balanced 10 k Ω
Signal-to-Noise Ratio	122 dB 'A'-Weighted (typical), <i>maximum gain</i>
Frequency Response	20 Hz – 20 kHz \pm 0.1 dB 10 Hz – 122 kHz \pm 3 dB <i>unity gain</i>
THD + N	-91 dB (0.0028%) @ -1 dB
High-Pass Filter	75 Hz knee frequency, 18 dB/octave, switchable per channel
Common Mode Rejection Ratio	-65 dB @ 1 kHz

Instrument Inputs	
<i>All measurements taken at minimum gain, Z In: Low, unless otherwise stated, $R_s = 600 \Omega$. Measurements taken at the analogue outputs</i>	
Gain Range	+10 to +40 dB continuous, using Trim pot
Maximum Input Level	+18 dBu
Input Impedance	Low: 470 k Ω , High: 2.4 M Ω
Signal-to-Noise Ratio	100 dB 'A'-Weighted
Frequency Response	20 Hz – 20 kHz \pm 0.1 dB 10 Hz – 110 kHz \pm 1.2 dB
THD + N	-83 dB (0.0071%) @ -1 dBFS
High-Pass Filter	75 Hz knee frequency, 18 dB/octave, switchable per channel

Connectivity	
Front panel	
Instrument inputs	4 x 1/4" mono jack
Rear Panel	
Microphone inputs	8 x XLR-3 female
Line level inputs Line level outputs	8 x 1/4" balanced jack 1 x DB25 female (AES59 Tascam Analogue)
A-D inputs	1 x DB25 female (AES59 Tascam Analogue)
Digital Card Slot	
Compatible card	ISA ADN8

Crosstalk	
<i>All measurements taken at minimum gain, Z In: Medium</i>	
Microphone Inputs	-60 dB, 20 Hz – 20 kHz
Line Inputs	-80 dB, 20 Hz – 20 kHz
Instrument Inputs	-80 dB, 20 Hz – 20 kHz

Dimensions	
Height	88mm / 3.46"
Width	482mm / 18.98"
Depth	325mm / 12.8"

Weight	
Weight	7.05 kg / 15.55 lbs

Power	
PSU	1 x Internal, 100 – 240 V, 50 / 60 Hz
Consumption	35 W.

Environmental	
Operating Temperature	40°C / 104°F Maximum ambient operating temperature

Focusrite RedNet Warranty and Service

All Focusrite products are built to the highest standards and should provide reliable performance for many years, subject to reasonable care, use, transportation and storage.

Very many of the products returned under warranty are found not to exhibit any fault at all. To avoid unnecessary inconvenience to you in terms of returning the product please contact Focusrite support.

In the event of a Manufacturing Defect becoming evident in a product within 12 months from the date of the original purchase Focusrite will ensure that the product is repaired or replaced free of charge.

A Manufacturing Defect is defined as a defect in the performance of the product as described and published by Focusrite. A Manufacturing Defect does not include damage caused by post-purchase transportation, storage or careless handling, nor damage caused by misuse.

Whilst this warranty is provided by Focusrite the warranty obligations are fulfilled by the distributor responsible for the country in which you purchased the product.

In the event that you need to contact the distributor regarding a warranty issue, or an out-of-warranty chargeable repair, please visit: pro.focusrite.com/rest-of-the-world

The distributor will then advise you of the appropriate procedure for resolving the warranty issue. In every case it will be necessary to provide a copy of the original invoice or store receipt to the distributor. In the event that you are unable to provide proof of purchase directly then you should contact the reseller from whom you purchased the product and attempt to obtain proof of purchase from them.

Please do note that if you purchase a Focusrite product outside your country of residence or business you will not be entitled to ask your local Focusrite distributor to honour this limited warranty, although you may request an out-of-warranty chargeable repair.

This limited warranty is offered solely to products purchased from an Authorised Focusrite Reseller (defined as a reseller which has purchased the product directly from Focusrite Audio Engineering Limited in the UK, or one of its Authorised Distributors outside the UK). This Warranty is in addition to your statutory rights in the country of purchase.

Registering Your Product

For access to Dante Virtual Soundcard, please register your product at: www.focusrite.com/register

Customer Support and Unit Servicing

You can contact our dedicated RedNet Customer Support team free of charge:

Email: proaudiosupport@focusrite.com

Phone (UK): +44 (0)1494 836384

Phone (USA): +1 (310) 450-8494

Troubleshooting

If you are experiencing problems with your ISA 828 MkII, we recommend that in the first instance, you visit our Support Help Centre at: focusritepro.zendesk.com.